

ProTec 160 – for high roadwork safety.

H1 / W4 / ASI B



Safety by Berghaus





ProTec 160 has a high containment level with minimum space requirements.

Mobile crash barriers in roadworks clearly enhance traffic safety. Their containment capacity prevents road users from leaving the carriageway and colliding with oncoming traffic, while also providing safe working conditions on site.

The mobile crash barrier ProTec 160 has been successfully tested for containment level H1 and effective range W4 at TÜV-Süd in Munich. The 80 centimeters high ProTec 160 crash barrier with containment level H1 is an ideal addition to the ProTec family. With its great stability of 300 kg per meter while taking up only minimum space, ProTec 160 is suitable particularly for professional traffic safety in transition zones, such as application E pursuant to ZTV-SA. Mobile crash barriers in the ProTec family are the ideal solution for professional traffic safety at construction sites on roads and motorways, particularly in constricted roadworks situations.

No matter what your particular application is, mobile crash barriers in the ProTec family always put you on the safe side!

Advantages of the ProTec 160 at a glance:

- positive appraisal and approval by BAST
- narrow structural width needs minimum space requirements
- reflectors mounted in protected recess
- generous water drainage opening under the crash barrier
- no risk of aquaplaning or of dirt accumulating in front of the crash barrier
- rubber-based stands protect the road surface
- quick and easy installation
- transition elements available for all ProTec systems
- low element weight for high transport loading volume

The ProTec family consists of several successfully tested mobile crash barriers – for all application areas of mobile road restraint systems pursuant to the ZTV-SA. Despite differing shapes and structures, all mobile crash barriers in the ProTec family can be combined with each other and fitted together with force-fit connections. Mobile crash barriers in the ProTec family can also be combined with stationary restraint systems or mobile systems by other manufacturers with a force-fit connection.

ProTec 160: Safe – compact – economical.

Technical data

Containment level	H1
Effective range	W4
ASI value	B
Structural width	0.50m
Height	0.80m
Element length	10m
Minimum installation length	120m
Ground anchoring	yes (only at the start)
Weight per m	300 kg
Test date	14.+15/09/2009
Test number	BAST 2010 7E 54

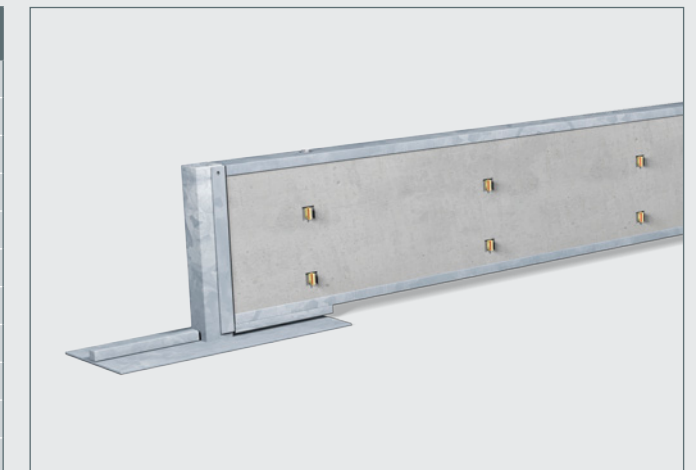

Standard element 10m

Test conditions as per DIN EN 1317-2

Acceptance test	TB 11 / TB42
Test vehicle	PKW / LKW
Weight	0.9t / 10t
Impact angle	20° / 15°
Speed	100 km/h / 70 km/h



ProTec systems warrant a generous water drainage opening of 8m in length per 10m element.



A stand is always fitted to every element. Just two screws are used every 10 meters.

Combination example for a force-fit connection across the whole ProTec family.

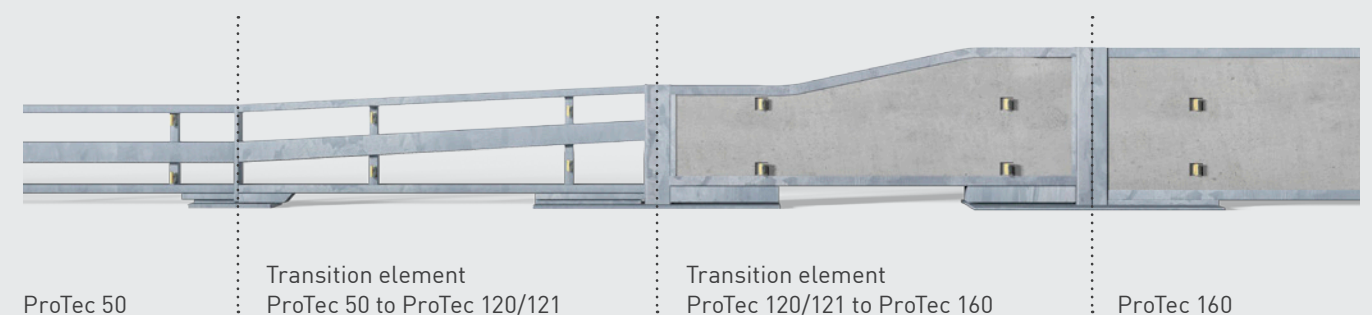



Peter Berghaus GmbH

Herrenhöhe 6

51515 Kürten-Herweg

T +49 (0)2207 9677-0

F +49 (0)2207 9677-80

mail@berghaus-verkehrstechnik.de

www.berghaus-verkehrstechnik.de



Subject to technical changes and errors.
Products may differ from illustrations shown.
All details are approximate.